

---

# ELECTRICAL AND INSTRUMENTATION (E & I) ENGINEERING FOR OIL AND GAS FACILITIES



## WHAT YOU WILL GAIN:

- Skills and competencies in E&I oil and gas engineering
- Knowledge of the latest technologies in E&I oil and gas engineering
- Key techniques in operating your facility to the highest level of safety and in protecting the environment
- Decades of real experience distilled into the course presentations and materials
- Guidance from real E&I oil and gas experts in the field
- Hands-on, practical knowledge from the extensive experience of instructors, rather than the theoretical information from books and colleges
- Networking contacts in the oil and gas industry

## WHO SHOULD ATTEND:

This workshop is ideal for you if you are seeking expertise in the oil and gas business, including:

- Recent graduate electrical, instrumentation or mechanical engineers
- Chemical engineers
- Electrical engineers
- Experienced electricians
- Fire and gas engineers
- Instrument and control systems engineers
- Instrument and process control technicians or technologists
- Instrument fitters
- Mechanical engineers

Even if you are highly experienced you will find this a great way to become familiar with the oil and gas technology as quickly as possible.



## The Workshop

There is a growing shortage, and hence opportunity, for Electrical and Instrumentation (E&I) technicians, technologists and engineers in the oil and gas industry. This is due to an increasing need for higher technology methods of obtaining and processing oil and gas as it is a finite declining resource. The price of oil is heading upwards steadily, thus making personnel and their associated oil and gas expertise in these industries even more valuable. The technical challenges of extracting oil and gas are becoming ever more demanding, with increasing emphasis on more marginal fields and previously inaccessible zones such as deep oceans, Polar regions, Falkland Islands and Greenland. The aim program is to provide you with core E&I engineering skills to enhance your career, and to benefit your firm.

This course provides a whole spectrum of activities ranging from basic electrical and instrumentation engineering to advanced practice including hazardous areas, data communications along with a vast array of E&I equipment utilised in an oil and gas environment as well as practical treatment of electrical power systems and instrumentation within the oil, gas, petrochemical and offshore industries. Whilst there is some theory this is used in a practical context giving you the necessary tools to ensure that the E&I hardware is delivering the results intended. No matter whether you are a new electrical, instrumentation or control technician/technologist/graduate engineer or indeed, even a practising facilities engineer, you will find this course beneficial in improving your understanding, skills and knowledge. This is a 5-day intensive workshop, covering considerable material, if you are looking for a far higher level of knowledge and competencies, you can undertake our 18 month in-depth Advanced Diploma of E&I Engineering for Oil and Gas Facilities through the EIT.

## On-Site Training

- ✓ **SAVE** over 50% by having an IDC workshop presented at your premises.
- ✓ Customise the training to **YOUR** workplace.
- ✓ Have the training delivered when and where you need it.

Contact us for a **FREE** proposal.

## The Program

### INTRODUCTION – SETTING THE SCENE IN OIL AND GAS E & I ENGINEERING

- Fundamentals of electrical engineering
- Fundamentals of instrumentation, measurement and process control engineering

### INSTRUMENTATION AND CONTROL

- General instrumentation standards in oil and gas
- Best practice in process, electrical and instrumentation drawings and documentation
- Process instrumentation
- Calibration, installation and maintenance of instruments
- Process control basics
- Control valves sizing, selection and maintenance (including pressure relief valves)
- Programmable Logic Controllers
- SCADA systems
- Distributed control systems
- Industrial data communications (including Fieldbus and industrial Ethernet)
- Safety instrumentation and emergency shutdown systems for oil and gas (IEC 61511 and IEC 61508) – basic introduction
- Wellhead and flowline control – control systems
- Emergency wellhead blowout controls

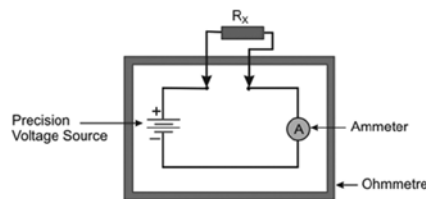

### SPECIALISED APPLICATIONS IN OIL AND GAS

- Power generation
- Cathodic protection
- Compressor control (including surge control)
- Drilling control systems and instrumentation
- Subsea instrumentation and control systems
- Pig launcher/receiver systems
- Critical flare knock out drum controls and instrumentation
- Flare flame front generator and ignition monitoring system
- Distributed control systems

### ELECTRICAL ENGINEERING IN OIL AND GAS

- Electrical drawings, documentation and schematics
- Transformers
- Troubleshooting, maintenance and protection of AC electrical motors
- Power distribution
- Power system protection and co-ordination (including fault calculations/stability and protective relays)
- Switchgear and distribution systems
- Cables and wires – maintenance and installation practice
- Variable (or adjustable) Speed Drives (VSDs) for instrumentation and control systems
- Electrical safety
- Earthing/grounding, power system harmonics and power quality – onshore/offshore
- Lightning and surge protection
- Uninterruptible Power Supplies (UPSs), batteries and battery chargers
- Emergency power supplies
- Electrical equipment in hazardous areas
- Electrical applications to an oil and gas platform and site

### SUMMARY, OPEN FORUM AND CLOSING

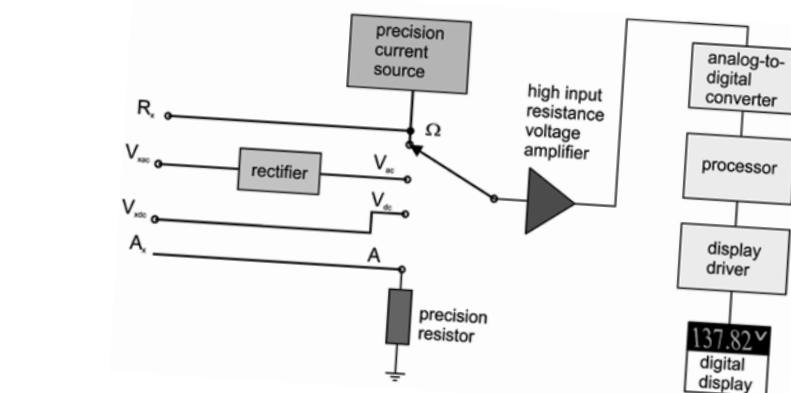

## Practical Sessions

This is a practical, hands on workshop enabling you to work through practical exercises which reinforce the concepts discussed.

**To gain full value from this workshop, please bring your laptop/notebook computer.**